

WORKING BEYOND LIMITS



POWERBULLY 12D



Payload
11,500 kg | 25,400 lbs



Ground pressure
0.24 kg/cm² | 3.41 psi



Fording depth
1,300 mm | 51.2"



Capacity heaped (ISO 6483)
6.4 m³ | 8.4 yd³



Tare weight
14,880 kg | 32,800 lbs



Gradeability
60 % uphill & downhill, 40 % sidehill



Max. speed
14.5 km/h | 9.0 mph

ENGINE & POWER

Type	Cummins B6.7 Turbo Diesel
No. of cylinders	6
Displacement	6.7 l / 6,700 ccm
Power Output @ 2,000 rpm	209 kW / 285 hp
Max. torque @ 1,500 rpm	1,288 Nm 950 ft lb
Emission standard	EU Stage V Tier 4f
Drive train: Hydrostatic Bosch Rexroth drive train	

TANK VOLUMES

Diesel	250 l 66 gal
AdBlue	38 l 10 gal

CABIN

Wide or narrow cab	10.4" Touch display	Sun blind
Suspended cab	Armrest with controls	
ROPS / FOPS (Level I and II) certified	Heating, temperature and fan control	Illumination
2 axis inclination sensor	12V power outlet	6 LED working lights front and rear (6,000 lm)
Adjustable operator's seat	USB charging port	
	Mobile phone tray	

OPTIONS

Safety	Comfort	Cold start	Other
Premium LED working lights (10,000 lm)	Wide cab	Auxiliary heating	Telematics
Beacon light	Air suspended operator's seat	Supply pressure reduction	Reversible fan
Auxiliary lights (High and low beam, rear light, indicators)	Air conditioning	Engine block heater	Mechanical tailgate
Rear view camera	Adjustable steering wheel	Tank heaters to preheat hydraulic oil	Frame extension front 700 mm 27.5"
360° camera	Heated, electrically adjustable mirrors	Heated fuel filter	
Foldable front brush guard	Radio with Bluetooth and a hands-free kit		
FOPS level II protective grid			
Hydraulic winch (Tractive force : 11 t 22,250 lbs)			

PowerBully
TRACK CARRIER

POWERBULLY 12D

DIMENSIONS

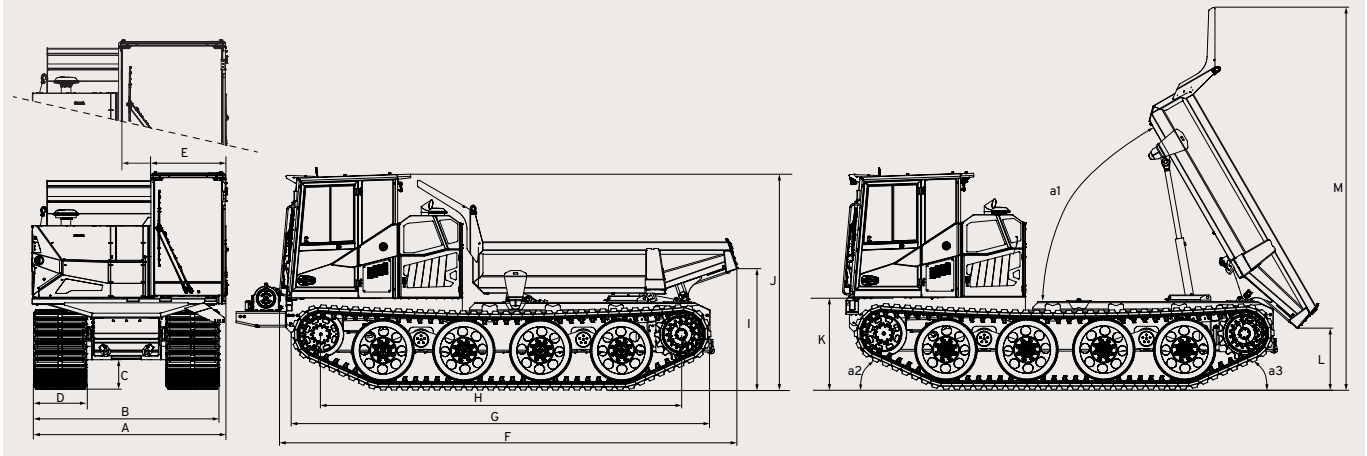

A 2,590 mm | 102"

B 2,500 mm | 98"

C 532 mm | 21"

D 750 mm | 29.5"

E 982 mm | 38.7"

F 6,375 mm | 250"

G 5,840 mm | 230"

H 5,021 mm | 198"

I 1,760 mm | 69"

J 3,005 mm | 118"

K 1,300 mm | 51.2"

L 852 mm | 33.5"

M 5,314 mm | 209"

a1 62° **a2** 24° **a3** 25°

Option: Wide Cabin **E** 1,412 mm | 55.6"

Option: Frame extension front 700 mm | 27.5" and winch

HARDOX DUMP BODY / AUTOMATIC LOWERING

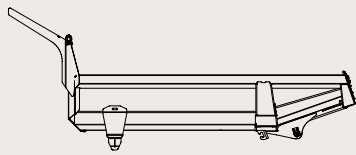

Capacity heaped (ISO 6483) 6.4 m³ | 8.4 yd³

Capacity leveled 4.5 m³ | 5.9 yd³

Length 3,683 mm | 145"

Width 2,444 mm | 96"

Side wall height 652 mm | 25.7"

OFF-ROAD ABILITIES

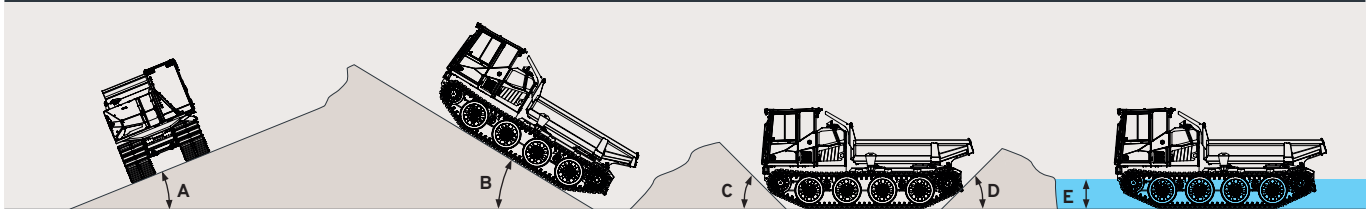

A Sidehill 40% | 22°

B Uphill | Downhill 60% | 31°

C Approach angle 45°

D Departure angle 45°

E Fording depth 1,300 mm | 51.2"

Approach and departure angles deviating with frame extensions



Learn more about PowerBully:
powerbully.com
sales@powerbully.com

PowerBully
TRACK CARRIER